



Highway Structures & Bridges
Inspection & Assessment

CS 468

Assessment of Freyssinet concrete hinges in highway structures

(formerly BE 5/75)

Revision 1

Summary

This document sets out the requirements for the assessment of Freyssinet concrete hinges used in highway structures. It also provides advice on the inspection and management of Freyssinet concrete hinges.

Application by Overseeing Organisations

Any specific requirements for Overseeing Organisations alternative or supplementary to those given in this document are given in National Application Annexes to this document.

Feedback and Enquiries

Users of this document are encouraged to raise any enquiries and/or provide feedback on the content and usage of this document to the dedicated Highways England team. The email address for all enquiries and feedback is: Standards_Enquiries@highwaysengland.co.uk

This is a controlled document.

Contents

Release notes	2
Foreword	3
Publishing information	3
Contractual and legal considerations	3
Introduction	4
Background	4
Assumptions made in the preparation of this document	5
Mutual Recognition	5
Symbols	6
Terms and definitions	7
1. Scope	8
Aspects covered	8
Implementation	8
Use of GG 101	8
2. Inspection and material properties	9
General	9
Hinge inspection	9
Hinge geometry	10
Material properties	10
Concrete	10
3. Assessment	11
General	11
Hinge analysis	11
Assessment of resistance of rectangular hinges	12
Transverse reinforcement	12
Shear resistance	14
Assessment of resistance of circular hinges	14
Transverse reinforcement	15
Shear resistance	15
Collision shear resistance for circular and rectangular hinges	15
4. Normative references	17
5. Informative references	18
Appendix A. Typical illustrations of hinge features	19
Appendix B. Basis for the rotation and stress distribution at the throat of hinges	24
B1 Rectangular hinge	24
B2 Circular hinge	26

Release notes

Version	Date	Details of amendments
1	Mar 2020	Revision 1 (March 2020) Update to references only. Revision 0 (November 2019) CS 468 replaces BE 5/75. This full document has been re-written to make it compliant with the new Highways England drafting rules. BE 5/75 has been changed from a design to an assessment document. The design rules have been updated and modified such that the document is used for the serviceability limit state assessments of existing structures with either rectangular or circular unreinforced concrete hinges.

Foreword

Publishing information

This document is published by Highways England.

This document supersedes BE 5/75, which is withdrawn.

Contractual and legal considerations

This document forms part of the works specification. It does not purport to include all the necessary provisions of a contract. Users are responsible for applying all appropriate documents applicable to their contract.

Introduction

Background

This document provides requirements and advice for the assessment of existing Freyssinet concrete hinges in highway structures. This document supersedes BE 5/75, which has been withdrawn.

Concrete hinges provide release of bending moment in a member by their action which approximates to a pin connection. The pin action is achieved by notching the member to form a throat which transmits axial and shear forces while relieving the bending moments. Concrete hinges have been in use since the end of the nineteenth century, with different types of hinges used to transmit the member forces through the throat.

Freyssinet hinges make use of the high compressive strength which is developed in the throat due to the tri-axial confinement of the concrete so that there is no primary structural requirement for reinforcement to pass through the throat. Freyssinet hinges were first used on the Chandelier Bridge in 1923 Freyssinet 1923 [Ref 4.I].

Design models for Freyssinet concrete hinges have been developed in Germany, Sweden, Great Britain, France and the Netherlands (see Proc ICE Paper 1400020 [Ref 2.I]).

In the early 1960's, the Cement and Concrete Association (now the Concrete Society) published research, undertaken by Base, into Freyssinet hinges which included extensive laboratory testing, as reported in CCA TRA 359 [Ref 6.I] and CCA Research Report No. 17 [Ref 5.I]. Based on the experimental results, Sims & Bridle 1964 [Ref 7.I] developed empirical rules for the design of Freyssinet concrete hinges, which were later used in England for the design of some bridges on the M1 motorway Proc ICE Paper 1400020 [Ref 2.I]. During this period concrete hinges were also used on many other bridges as support members and rocker bearings.

In 1975, the Highways Agency (now Highways England) published the technical memorandum BE 5/75, 'Rules for the design and use of Freyssinet concrete hinges in highway structures'. BE 5/75 was based on the model for calculation developed by Sims & Bridle 1964 [Ref 7.I] from tests by Base CCA TRA 359 [Ref 6.I].

The concrete hinge is an area of high stress concentration which is densely reinforced in the end blocks. The reinforcement and the highly profiled geometry of the notch create difficulty to achieve the required level of compaction of the concrete. The load bearing capacity strongly depends on the ability of the tensile reinforcement in the end blocks to resist the tensile splitting forces. Reinforcement across the hinge throat is not necessary under the multi-axial state of stress in the throat. Excessive reinforcement disturbs the state of stress in the hinge throat and can lead to shrinkage cracks as shown by Base in CCA TRA 359 [Ref 6.I], cited in Proc ICE Paper 1400020 [Ref 2.I].

The existing Freyssinet concrete hinges on motorway and all purpose trunk road bridges in England have generally been shown to be structurally reliable to date. Concrete hinges themselves require low maintenance and can therefore be very durable if designed and constructed properly (see Marx & Schacht 2010 [Ref 1.I]).

However, the hinge areas are vulnerable to cracking and concrete spalling which may lead to water ingress and subsequent corrosion of the reinforcement. Past inspections have recorded instances of sub-standard workmanship, difficulty to gain access for inspection, hinges being buried below ground level, issues related with tension in hinges, and non-compliant throat details.

Concrete hinges are also vulnerable in lateral shear due to vehicle collision forces. The assessment values of collision forces as given in CS 453 [Ref 7.N] have increased significantly since the introduction of the concrete hinges.

BE 5/75, which was primarily a design document, has been applied to previous assessments of concrete hinges via departures from standard, necessary because of the limitations of BE 5/75 which can be summarised as follows:

- 1) BE 5/75 was written as a working stress document, prior to the introduction of limit state design;

- 2) BE 5/75 addressed a specific design configuration with a rectangular shaped throat for a limited range of material properties;
- 3) BE 5/75 proposed a theory which is shown to be adequate for the prescribed design configuration but not readily adaptable to other configurations; and,
- 4) the complex behaviour of the concrete within and around the hinge not being addressed in detail.

The use of concrete hinges in new design is not permitted, unless there is absolutely no alternative solution, such as in situations where the articulation of an existing the bridge being widened has to be maintained. In such cases, the hinges are required to be designed to be accessible for inspection and maintenance CD 350 [Ref 8.N].

In 1977, Crossley published design recommendations for circular hinges which included full scale laboratory testing Crossley 1977 [Ref 3.I]. Crossley proposed design charts based on experiments and compared his results by adapting the theory from BE 5/75. This update of BE 5/75 has incorporated the design recommendations by Crossley for use in the assessment of existing circular hinges.

A critical review on concrete hinges was carried out by who compared the different theories in common use worldwide. While the theory in BE 5/75 had some limitations, it was seen to be adequate within the available knowledge.

This document updates and adapts BE 5/75 for use in the assessments of concrete rectangular and circular hinges. The findings from research studies published after the publication of BE 5/75, as well as provisions from previous departures from standards relating to the assessment of concrete hinges, have been incorporated as appropriate.

Assumptions made in the preparation of this document

The assumptions made in GG 101 [Ref 3.N] apply to this document.

Mutual Recognition

Where there is a requirement in this document for compliance with any part of a "British Standard" or other technical specification, that requirement may be met by compliance with the Mutual Recognition clause in GG 101 "Introduction to the Design Manual for Roads and Bridges".

Symbols

Symbols

Symbol	Definition
A_{st}	area of transverse reinforcement provided in the tensile zone (mm^2)
A_{stl}	area of longitudinal reinforcement provided in the tensile zone (mm^2)
a	width of the throat (mm)
a_r	width of shoulder (mm)
a_1	effective width of the throat (mm)
b	length of the throat (mm)
b_r	length of shoulder (mm)
b_1	effective length of the throat (mm)
c	length of member (or end block) (mm)
d	width of member (or end block) for a rectangular hinge or diameter of member (or end block) for a circular hinge (mm)
d_1	effective throat diameter (mm)
E	modulus of elasticity (kN/mm^2)
E_{cm}	short term modulus of elasticity for concrete (kN/mm^2)
f_{cu}	characteristic or worst credible concrete cube strength (N/mm^2)
f_{st}	permissible tensile strength of steel reinforcement (N/mm^2)
h_e	effective height of the throat element (mm)
N	total axial force (normal force) on the throat (N)
Q	shear force on the hinge throat (N)
Q_y	shear force on hinge throat (N) acting perpendicular to the axis of rotation
R	resultant force (N) of the axial and shear forces acting over the hinge
t	thickness of the throat (mm)
Z_1, Z_2, Z_3	transverse tensile forces (N) in the faces of end blocks
Z_y	transverse tensile stresses (N/mm^2)
β	angle of inclination of the notch surface to the horizontal (degrees)
γ_{fl}	partial load factor
γ_{f3}	partial factor for load effects
γ_m	partial safety factor for strength
ϕ_e	equivalent rotation of hinge about the axis of rotation (rads)
ϕ_p	rotation of hinge under permanent loads (rads)
ϕ_s	rotation of hinge under variable and temperature loads (rads)

Terms and definitions

Terms and definitions

Term	Definition
Effective throat diameter	The diameter of the circular hinge to be used in assessment which can include allowance for spalling.
Effective throat length	The length of rectangular hinge along the axis of bending to be used in assessment which can include allowance for spalling.
Effective throat width	The width of the rectangular hinge to be used in assessment which can include allowance for spalling.
End block	<p>The part of member adjacent to the hinge within which the stress distributes from the throat to a constant value across the width of the member.</p> <p>NOTE: For hinge assessment the tensile zones in the end block extend above and below the throat for a distance from the horizontal centre line of the throat equal to the width of the rectangular member.</p>
Notch	The recesses in the member, forming the hinge throat.
Notch profile	<p>The shape of the notch where it meets the throat.</p> <p>NOTE: Notch profile can be curved or straight to member axis.</p>
Shoulder	<p>The part between face of the member and edge of throat.</p> <p>NOTE: Minimum distance from face of member and edge of throat is taken as 75mm.</p>

1. Scope

Aspects covered

1.1 This document shall be used for the assessment of existing Freyssinet concrete hinges with:

- 1) rectangular or circular throat section; and,
- 2) profiled notch geometry.

NOTE Refer to Appendix A - Figure A.1 for typical illustrations of a rectangular hinge block and definitions of terminology.

1.2 This document shall be used for concrete hinges:

- 1) with no reinforcement through the throat; or,
- 2) in which the area of reinforcement through the throat of the hinge does not exceed 5% of the cross sectional area of the throat.

NOTE 1 Freyssinet concrete hinges assume that reinforcement through the throat of the hinge does not participate to transmit forces through the throat.

NOTE 2 Excessive reinforcement disturbs the state of stress in the throat and can cause shrinkage cracks in the hinge throat.

1.3 This document shall be used where the concrete cube strength is not less than 30 N/mm² for the hinge throat and end blocks.

NOTE A minimum concrete cube strength of 30 N/mm² is required, based on testing, for the assumed action of splitting the end blocks and the development of high confined strengths at the throat.

1.4 Rotation of the rectangular section hinge shall be only in one plane, that is about the longitudinal axis.

1.5 This document shall apply to concrete hinges with:

- 1) throat width within the range of 50mm - 250mm; and,
- 2) throat height less than half the width, up to a maximum of 50mm.

1.6 This document shall not be used for the assessment of:

- 1) bridge with deck hinges; or,
- 2) hinges with no primary requirement to carry axial forces.

NOTE The structural assessment of deck hinges is covered in CS 467 [Ref 4.N].

Implementation

1.7 This document shall be implemented forthwith on all schemes involving the assessment of existing Freyssinet concrete hinges in highway structures on the Overseeing Organisations' motorway and all-purpose trunk roads according to the implementation requirements of GG 101 [Ref 3.N].

1.8 Where this document duplicates or covers the requirements in existing standards during a period of co-existence, it shall take precedence unless otherwise agreed with the Overseeing Organisation.

Use of GG 101

1.9 The requirements contained in GG 101 [Ref 3.N] shall be followed in respect of activities covered by this document.

2. Inspection and material properties

General

2.1 Inspection of highway structures which include concrete hinges shall be carried out in accordance with CS 450 [Ref 2.N], CS 454 [Ref 1.N] and as given in this section.

Hinge inspection

2.2 Where accessible, hinge positions shall be inspected for signs of deterioration, for example due to water ingress and corrosion of the reinforcement.

NOTE 1 The throat concrete is not always visible where:

- 1) the entire hinge is buried below ground; or,
- 2) material used for notching the faces of the throat was left in place after construction.

NOTE 2 Previous inspections have noted wood and filler board used as hinge notch former on some structures.

2.3 The hinge positions shall be examined for:

- 1) evidence of cracking across the throat;
- 2) spalling of concrete in the throat; and,
- 3) transverse cracking on the end blocks adjacent to the throat.

NOTE 1 Cracking of the concrete at the hinge is not a sign of failure of the hinge, but it is essential to limit water ingress to prevent corrosion of reinforcement.

NOTE 2 Spalling of concrete is acceptable where it is not progressive into the throat.

NOTE 3 Cracking generally occurs in the end blocks in areas where the tensile reinforcement provided cannot resist the tensile splitting forces.

2.4 The concrete in the throat area shall be inspected for local deformation or heave due to poor quality of workmanship around the hinge position.

NOTE 1 Tension cracking of the throat can have implications on the long term performance of concrete hinges.

NOTE 2 Deviations in the surface of the hinge throat are an indication of poor quality workmanship at the time of construction.

NOTE 3 The concrete in the end blocks adjacent to the hinge throat is reinforced and profiled. Heavy reinforcement can lead to substandard workmanship at construction due to lack of compaction, particularly where standard sized 20mm aggregate has been used. The recommendation was for the use of 10mm aggregate in the construction to ensure good compaction of the concrete.

2.4.1 The hinge may be assumed to have been propped prior to the application of permanent loading, unless otherwise stated in the construction history.

NOTE Hinges had to be supported during construction from the time of casting to the completion of the structure incorporating the throat to prevent rotation of the throat.

2.5 Where the hinge positions are buried or inaccessible for inspection, the structure shall be surveyed to establish any sign of movement or distress which has been caused by collapse of the hinge.

NOTE 1 Failure of the hinge throat is likely to cause distress or displacement elsewhere on the bridge superstructure. As structures with these hinges were built over 30 years ago, defects of this nature are apparent if a failure of the hinge is occurring or has occurred. The failure mode of the throat is expected to be gradual.

NOTE 2 Signs of movement or distress caused by collapse or rotation of the hinge can include displacement of the bridge joint and cracking of the carriageway surfacing over the hinged support and around the joint, respectively.

- 2.5.1 Where signs of movement are detected in a buried or inaccessible hinge position, the position should be exposed for further inspection.

Hinge geometry

- 2.6 Hinges covered by this document shall be rectangular or circular.
- 2.7 For rectangular hinges, where the notches of hinges have a curved profile, the effective throat width, a_1 , or, effective length, b_1 , shall be taken as the actual as-built dimensions recorded for the throat width, a , the throat length, b , respectively $a_1 = a$ or $b_1 = b$.
- 2.8 For circular hinges, where the notches of hinges have a curved profile, the effective diameter, d_1 , shall be taken as the actual as-built dimension recorded for the throat diameter, d .
- 2.9 Where the notches of hinges have straight profiles, the effective throat width, a_1 , effective length, b_1 , or effective diameter, d_1 , shall be taken as the as-built dimension reduced by the throat height, t .
 $a_1 = a - t$, $b_1 = b - t$, or $d_1 = d - t$.

NOTE 1 Appendix A - Figure A.3 illustrates a typical elevation showing formation of a V-notch on a circular hinge with a straight profiled throat.

NOTE 2 Full scale testing has shown that limited spalling of the concrete occurs across the width of the throat with a straight profile at serviceability limit state, to form a curved notch profile.

- 2.10 For rectangular hinges, the throat length shall include a minimum recess of 75mm between the throat and member edge at either end as shown in Appendix A - Figure A.2.

NOTE Full scale testing has shown that spalling occurs along either end of the length of a rectangular throat to an extent of 75mm from the member edge where no recess already exists.

- 2.11 Where spalling already exists, the effective width or length shall equal the intact measured dimension.

Material properties

Concrete

- 2.12 The characteristic or worst credible concrete cube strength for use in the assessment shall be determined in accordance with CS 455 [Ref 6.N].
- 2.13 The maximum concrete cube strength for the assessment of concrete hinges shall not be greater than 52.5 N/mm².
- NOTE The assessment resistance model and rules developed from experimental results are applicable for hinges with a concrete cube strength up to of 52.5 N/mm².*
- 2.14 The short term elastic modulus of elasticity shall be determined in accordance with CS 455 [Ref 6.N].

3. Assessment

General

3.1 Assessment of highway structures which include concrete hinges shall be in accordance with CS 454 [Ref 1.N], CS 455 [Ref 6.N], CS 453 [Ref 7.N] and as given in this section.

Hinge analysis

3.2 The assessment of concrete hinges shall be carried out at serviceability limit state.

NOTE 1 The serviceability limit state is characterised by the onset of water ingress to cause corrosion of the reinforcement as a result of:

- 1) cracking across the throat due to tension or lift-off;
- 2) progressive spalling at the throat due to concrete crushing; or
- 3) transverse cracking of the end blocks due to the normal force from the hinge causing splitting.

NOTE 2 Experimental tests on concrete hinges have shown that ultimate failure of the concrete in the throat which occurs at high stresses up to $6f_{cu}$ is difficult to predict due to the complex stress configurations in the notch area.

NOTE 3 The methods for the assessment of resistance for rectangular and circular hinges at serviceability limit state used in this section have been derived from the empirical and experimental assumptions in Appendix B.

3.3 Allowance for deterioration and condition factor for assessment of resistance shall be determined in accordance with CS 455 [Ref 6.N].

3.4 Elastic analysis of the structure shall be carried out to determine the forces in the hinge and the coexistent hinge rotations under the loading in accordance with CS 454 [Ref 1.N] and CS 455 [Ref 6.N].

3.5 The rotation per unit axial load shall be determined for each condition of loading including the most lightly loaded condition.

NOTE The maximum value of rotation per unit axial load can occur under the most lightly loaded condition.

3.6 Analysis shall be carried out for load combinations in accordance with CS 454 [Ref 1.N].

3.7 Where existing Freyssinet concrete hinge supports are vulnerable to the effects of vehicular collision forces, they shall be assessed in accordance with CS 453 [Ref 7.N].

NOTE Freyssinet concrete hinges were not designed for use where there is a:

- 1) risk of collision with the structure causing damage or displacement of the hinge; or
- 2) resultant uplift on all or part of the hinge under any loading.

3.8 Existing pier or superstructure protection provided to a hinge vulnerable to the effects of vehicle collision forces shall be assessed in accordance with CS 453 [Ref 7.N].

3.9 The shear resistance across the throat of a vulnerable hinge under collision loading shall meet the requirement for collision assessment given in Equation 3.26.

3.9.1 Where multi-directional shear forces are acting concurrently on the hinge throat for a load combination, the shear force Q across the throat may be taken as the vector sum of these forces.

3.10 The partial factors shall apply at serviceability limit state in accordance with CS 454 [Ref 1.N] and CS 455 [Ref 6.N].

NOTE The value of γ_{f3} to be used at serviceability limit state is defined in CS 454 [Ref 1.N].

3.11 Where the bending stiffness of the hinge is included in the analysis, the bending action shall be represented by an effective member with the cross section of the throat and an effective height, h_e , of 125mm.

NOTE *The effective member for bending stiffness does not represent stress in the hinge.*

3.12 The effect of the reinforcement through the throat shall be ignored in the assessment of shear resistance of the hinge.

3.13 Where the minimum nominal cover to reinforcement is less than 25mm, the use of the assessment methods in this section shall be subject to technical approval in accordance with CG 300 [Ref 5.N].

Assessment of resistance of rectangular hinges

3.14 The resistance of the hinge throat to spalling of concrete crushing shall be in accordance with Equation 3.14:

Equation 3.14 Compressive resistance of hinge throat

$$N < \frac{2a_1b_1f_{cu}}{\gamma_m}$$

where:

- N is the axial force (N) on the throat;
- a₁ is the effective width of the throat (mm);
- b₁ is the effective length of the throat (mm);
- f_{cu} is the characteristic or worst credible cube strength (N/mm²), not greater than 52.5 N/mm²; and,
- γ_m is partial factor for material strength in accordance with CS 455 [Ref 6.N].

3.15 For the resistance of the throat against cracking due to uplift, the hinge rotation per unit axial load under all serviceability load conditions shall be in accordance with Equation 3.15:

Equation 3.15 Resistance against cracking

$$\frac{\phi_e}{N} < \frac{3h_e}{E_{cm}a_1^2b_1} = \frac{380}{E_{cm}a_1^2b_1}$$

where:

- ϕ_e = (ϕ_s + ϕ_p / 2) is the equivalent hinge rotation about the axis of rotation (rads);
- ϕ_p is the rotation of hinge under permanent loads (rads);
- ϕ_s is the rotation of hinge under variable and temperature loads (rads);
- a₁, b₁ are as previously defined;
- E_{cm} is the short term modulus of elasticity for concrete (kN/mm²); and,
- h_e is the effective height of the throat element (mm). Take 3h_e = 380mm with h_e ≈ 125mm.

Transverse reinforcement

3.16 The primary tensile force acting in the direction of the width of the member together with a secondary force acting horizontally at right angles to it shall be resisted by mats of reinforcement in the tensile zone.

NOTE 1 *The concentrated compressive force in the throat of the hinge induces transverse tensile forces in the adjacent members or end blocks. These forces extend over tensile zones above and below the throat for a distance from the horizontal centre line of the throat equal to the width of the rectangular member.*

- NOTE 2** All the mats in each member contained within the tensile zone with a high concentration within the half of the tensile zone nearest the throat.
- NOTE 3** Typical details of the types mat reinforcement that were recommended for use are provided in Appendix A - Figure A.5. The capacities of the mats are given in Appendix A- Table A.1. The mat information is only relevant where any of the types shown have been used on the existing end block being assessed.
- 3.17 The resultant of the axial and shear forces acting on the hinge shall be given by Equation 3.17:

Equation 3.17 Resultant force acting on hinge

$$R = \sqrt{N^2 + Q^2}$$

where:

- N is the axial force (N) on the throat;
- Q is the shear force (N) across the hinge throat; and,
- R is the resultant force (N) of the axial and shear forces acting over the hinge.

- 3.18 The resistance to cracking of the end block in the transverse direction due to the splitting action of the resultant hinge force shall be in accordance with Equation 3.18:

Equation 3.18 Resistance of end block to splitting action in transverse direction

$$R < \frac{8}{3} \times \frac{A_{st} \times f_{st}}{\left(1 - \frac{a_1}{d}\right)}$$

where:

- a₁ as previously defined;
- A_{st} is the total area of transverse reinforcement (mm²) provided in the tensile zone of each end block, where the tensile zone of each end block extends for a distance d (mm) from the horizontal centre line of the throat;
- d is the width of member (end block) (mm); and,
- f_{st} is the stress limit (N/mm²) in transverse reinforcement in end block, to be taken as 105 N/mm² for mild steel reinforcement and 150 N/mm² for high yield reinforcement.

- 3.18.1 The limiting stress for steel reinforcement shown on the as-built records may be used for f_{st} where available.
- 3.19 The resistance to cracking of the end block in the longitudinal direction due to the splitting action of the hinge forces, shall be in accordance with in Equation 3.19:

Equation 3.19 Resistance of end block to splitting action in longitudinal direction

$$R < 8 \times \frac{A_{stl} \times f_{st}}{\left(1 - \frac{b_1}{c}\right)}$$

where:

- A_{stl} is the total area of longitudinal reinforcement (mm²) provided in the tensile zone of each end block, where the tensile zone of each end block extends for a distance d from the horizontal centre line of the throat;
- b_1 as previously defined; and,
- c is the length member (end block) (mm).

Shear resistance

3.20 For the resistance to shear force across the hinge throat, the ratio of axial force to shear force for all load combinations excluding collision forces shall be in accordance with Equation 3.20:

Equation 3.20 Resistance to shear

$$\frac{N}{Q} > 3$$

where:

- N is the axial force (N) on the throat; and,
- Q is the shear force (N) across the hinge throat.

Assessment of resistance of circular hinges

3.21 For the resistance of the hinge throat to spalling of concrete due to crushing, the condition given in Equation 3.21 shall be satisfied for all serviceability load combinations:

Equation 3.21 Resistance of hinge

$$N < (1.4 - 66.67\phi_e) \times d_1^2 f_{cu} / \gamma_m$$

where:

- d_1 is the effective throat diameter (mm);
- f_{cu} is the characteristic or worst credible cube strength (N/mm²), not greater than 52.5 N/mm²;
- N is the axial force (N) on the throat;
- γ_m is partial factor for material strength in accordance with CS 455 [Ref 6.N];
- $\phi_e = \left(\phi_s + \frac{\phi_p}{2}\right)$ is the equivalent hinge rotation about the axis of rotation (rads);
- ϕ_p is the rotation of hinge under permanent loads (rads); and,
- ϕ_s is the rotation of hinge under variable and temperature loads (rads).

NOTE 1 Equation 3.21 ensures the satisfactory performance of a hinge despite the development of tension over part of the throat areas with slight but not progressive spalling in the compression face.

NOTE 2 Performance of the throat is also assured in the absence of a parabolic notch throat (i.e. circular or straight notch throat).

NOTE 3 Appendix B - Figure B.2 provides boundaries for the assessment load/rotation combinations which can be safely sustained together with the effects on the condition of the throat concrete.

3.22 For the resistance of hinge throat to cracking due to lift off, the rotation per unit force under all serviceability load combinations shall be in accordance with Equation 3.22:

Equation 3.22 Resistance against cracking

$$\frac{\phi_e}{N} < 3.4 \frac{h_e}{E_{cm} d_1^3} = \frac{425}{E_{cm} d_1^3}$$

where:

E_{cm} is the short term modulus of elasticity for concrete (kN/mm²);

h_e is the effective height of the throat element (mm) $h_e \approx 125\text{mm}$; and,

d_1 as previously defined.

Transverse reinforcement

3.23 The primary tensile force on a circular end block shall be resisted by spiral reinforcement in the tensile zone.

NOTE The concentrated compressive force in the throat of the hinge induces transverse tensile forces in the end blocks. These forces extend over tensile zones above and below the throat for a distance from the horizontal centre line of the throat equal to the diameter of the adjacent circular member. The spiral end block reinforcement extends over the tensile zones.

3.24 The resistance to cracking of the end block in the transverse direction due to the splitting action of the resultant hinge forces, shall be in accordance with Equation 3.24:

Equation 3.24 Resistance to splitting action in circular end block

$$R < \frac{8}{3} \times \frac{A_{st} f_{st}}{(1 - 0.9 \frac{d_1}{d})}$$

where:

A_{st} is the total area of transverse reinforcement (mm²) provided in the tensile zone of each end block, where the tensile zone of each end block extends for a distance d from the horizontal centre line of the throat;

d is the diameter of member (end block) (mm);

d_1 effective throat diameter (mm);

f_{st} is the stress limit (N/mm²) in transverse reinforcement in end block, to be taken as 105 N/mm² for mild steel reinforcement and 150 N/mm² for high yield reinforcement; and,

R is the resultant force (N) of the axial and shear forces acting over the hinge.

Shear resistance

3.25 The resistance to shear force across the hinge throat for all load combinations excluding collision forces, shall be in accordance with Equation 3.20.

Collision shear resistance for circular and rectangular hinges

3.26 For resistance to shear across the throat of circular and rectangular hinges assessed for actions including collision forces, the minimum ratio of axial force to shear force at serviceability shall be given by Equation 3.26:

Equation 3.26 Limit for collision shear resistance

$$\frac{N}{Q} > 2$$

where:

N and Q

are as previously defined.

4. Normative references

The following documents, in whole or in part, are normative references for this document and are indispensable for its application. For dated references, only the edition cited applies. For undated references, the latest edition of the referenced document (including any amendments) applies.

Ref 1.N	Highways England. CS 454, 'Assessment of highway bridges and structures'
Ref 2.N	Highways England. CS 450, 'Inspection of highway structures'
Ref 3.N	Highways England. GG 101, 'Introduction to the Design Manual for Roads and Bridges'
Ref 4.N	Highways England. CS 467, 'Risk management and structural assessment of concrete deck hinge structures'
Ref 5.N	Highways England. CG 300, 'Technical approval of highway structures'
Ref 6.N	Highways England. CS 455, 'The assessment of concrete highway bridges and structures'
Ref 7.N	Highways England. CS 453, 'The assessment of highway bridge supports'
Ref 8.N	Highways England. CD 350, 'The design of highway structures'

5. Informative references

The following documents are informative references for this document and provide supporting information.

Ref 1.l	Marx, S and Schacht, G. Marx & Schacht 2010, 'Concrete hinges - Historical development and contemporary use 3rd fib International Congress (2010)'
Ref 2.l	ICE Publishing. Schacht, G and Marx, S. Proc ICE Paper 1400020, 'Concrete hinges in bridge engineering'
Ref 3.l	Ribblesdale Cement Limited:ACT Project 1976-77. Crossley, A. N. Crossley 1977, 'Design recommendations for circular hinges'
Ref 4.l	Freyssinet, E. Freyssinet 1923, 'Le pont de Chandelier, Annales des ponts et chaussees, 1923'
Ref 5.l	Cement and Concrete Association. Base, G D. CCA Research Report No. 17, 'Tests on four prototype reinforced concrete hinges'
Ref 6.l	Cement and Concrete Association. Base, G D. CCA TRA 359, 'Tests on reinforced concrete hinge with a large design rotation'
Ref 7.l	Sims, F A and Bridle R J (1964). Sims & Bridle 1964, 'The design of concrete hinges'. Concrete and Constructional Engineering'

Appendix A. Typical illustrations of hinge features

The figure below (Fig. A.1) uses nomenclature from Fritz Leonhardt cited in Schacht & Marx, Proc ICE Paper 1400020 [Ref 2.1] .

Figure A.1 Typical rectangular concrete hinge

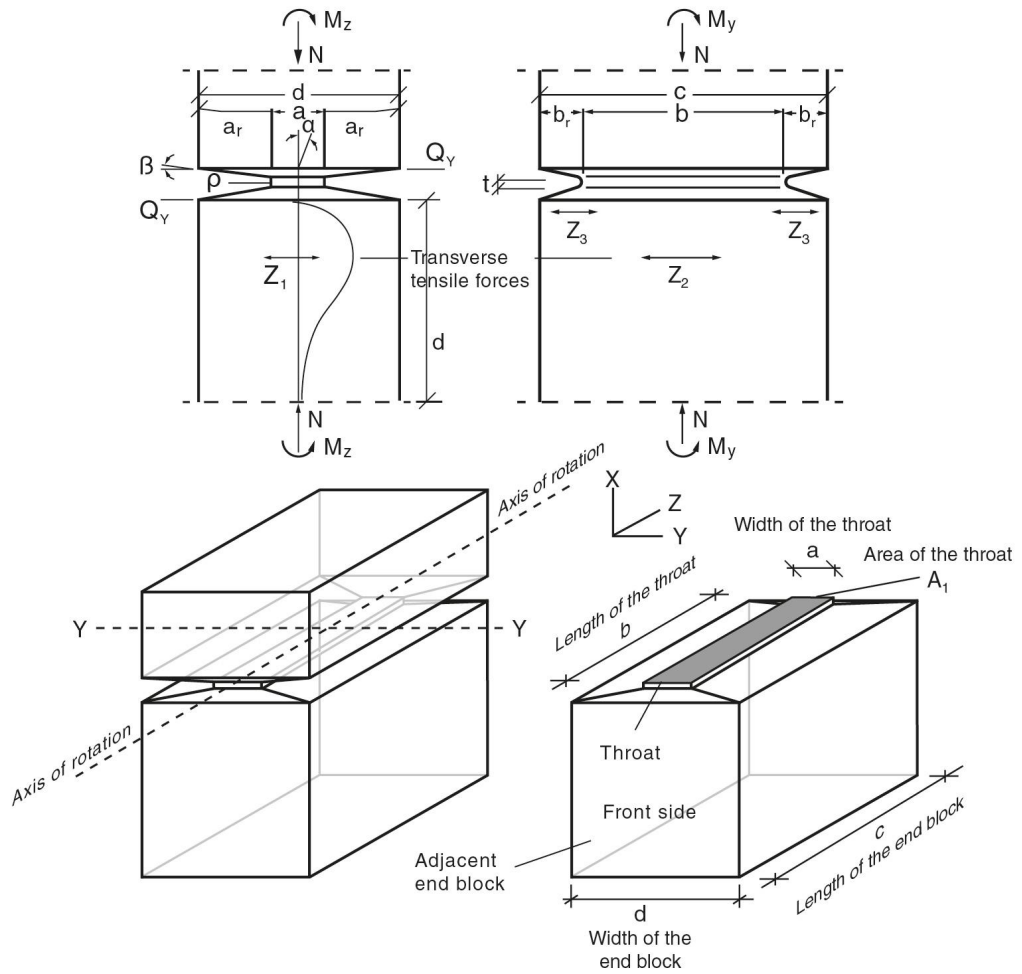

Figure A.2 Typical shape of a parabolic notch

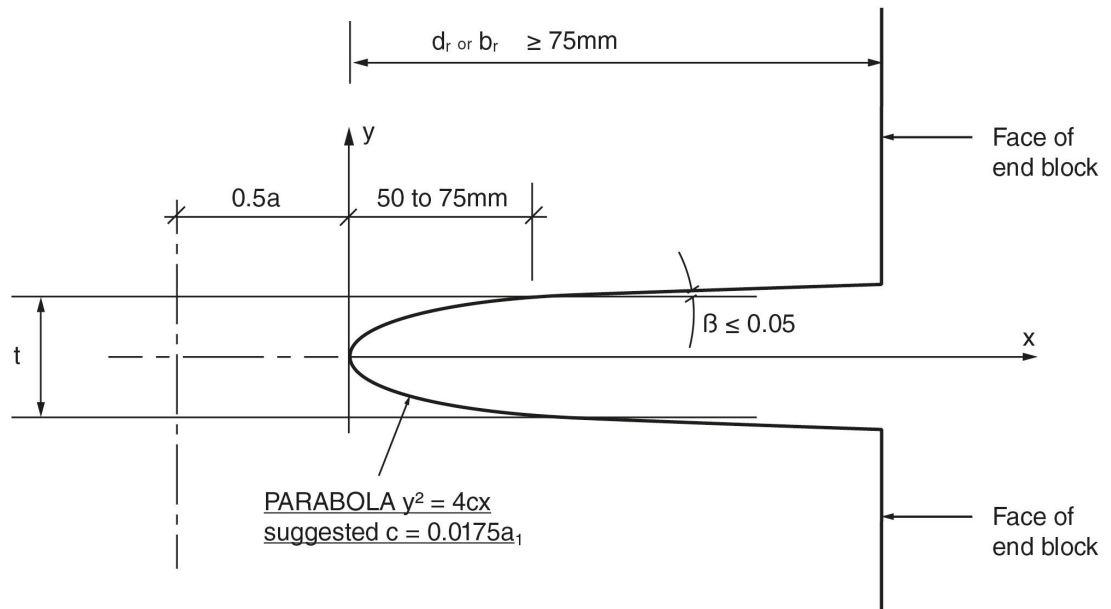

Figure A.3 Typical elevation showing formation of a v-notch from a straight notched throat on a circular hinge

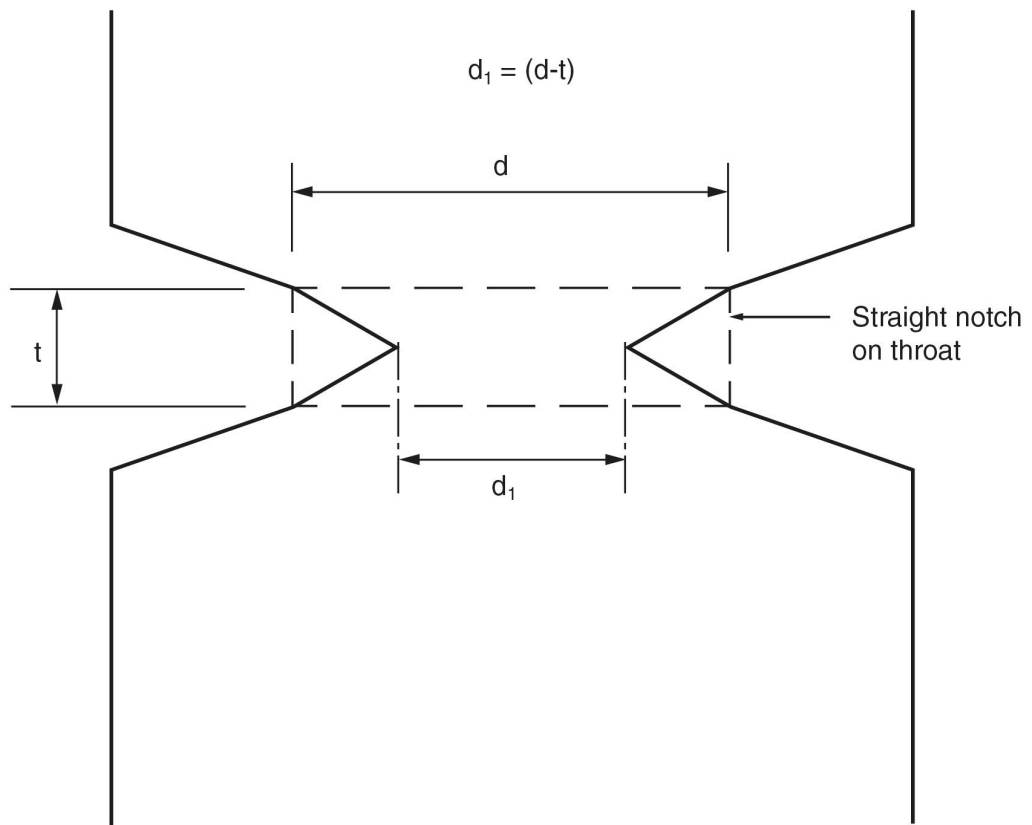
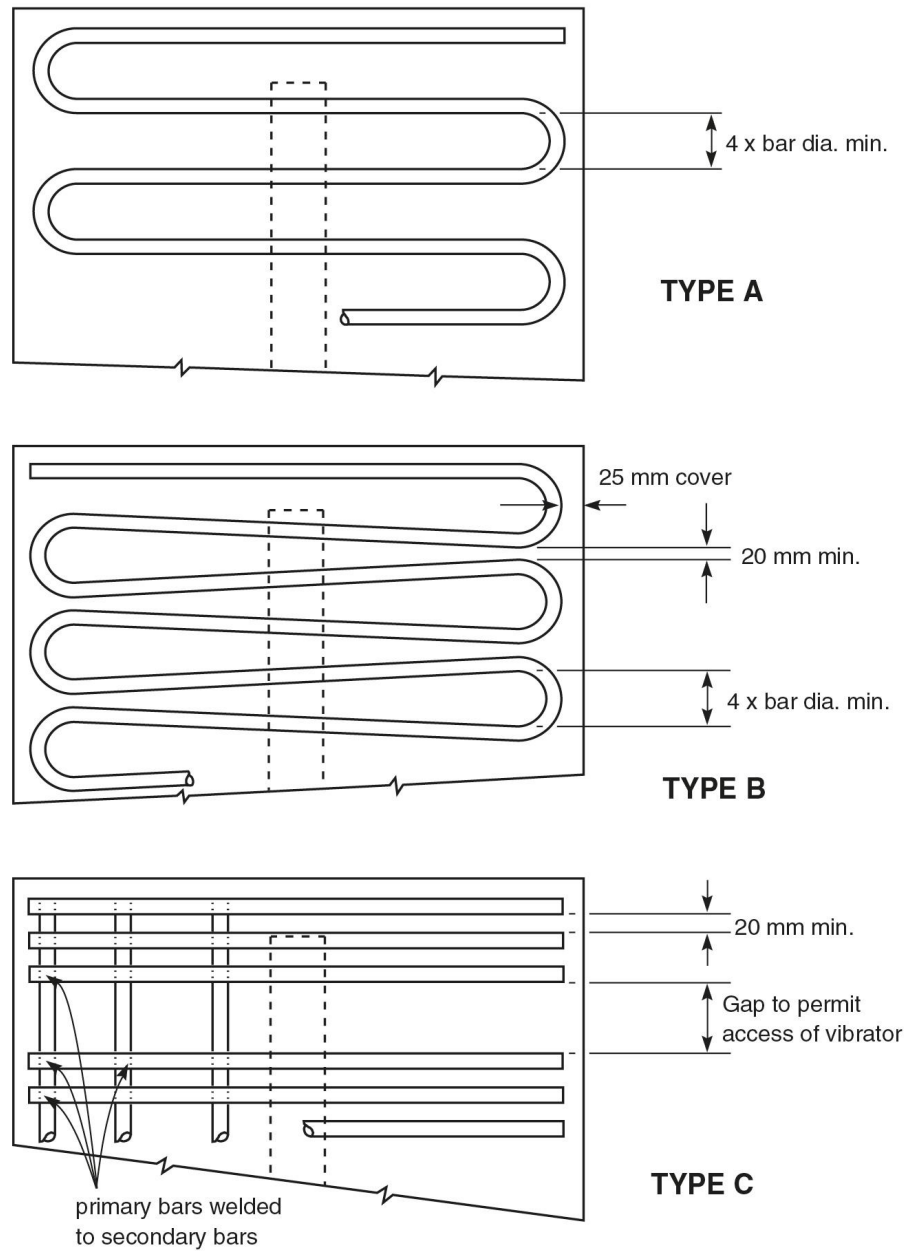

Figure A.4 Possible types of transverse mat reinforcement used on end blocks



Examples of typical mat reinforcement which were proposed for use on end blocks and their respective capacities.

Table A.1 Maximum cross-sectional areas and capacities of mat reinforcement

Bar diameter (mm)	Steel area per mat per metre (mm ²)	Tensile capacity per mat per metre (N)*	Number of mats required for a resultant hinge load $\sqrt{(N^2 + R^2)}$ of 1750 N/mm
Mat type A			
10	1570	165000	4.00
12	1810	190000	3.45
16	2410	253000	2.59
20	3140	329000	2.00
Mat type B			
10	1960	206000	3.19
12	2490	261000	2.51
16	3420	359000	1.83
20	4400	462000	1.42
Mat type C			
10	2590	272000	2.41
12	3730	392000	1.67
16	5630	591000	1.10
20	7850	824000	0.80
* Based on allowable steel stress of 105 N/mm ²			

Appendix B. Basis for the rotation and stress distribution at the throat of hinges

B1 Rectangular hinge

Experimental work and tests supported the development of the design approach in the withdrawn Technical Memorandum (Bridges) Rules for the Design and Use of Freyssinet Concrete Hinges in Highway Structures (BE 5/75) which was published by Highways Agency. Those experimental work and tests are referenced herein and form the basis for the assumptions on the rotation and stress distribution at the hinge throat for the assessment of rectangular hinges.

For the hinge to sustain large rotations without causing tensile stress in the throat, the width of the throat has to be assessed in relation to the required rotation. The experimental work showed that the behaviour of the concrete is elastic for short term loading and that under long term loading the creep is proportional to the initial stress.

It is therefore possible to calculate from elastic considerations the rotation, ϕ which if rapidly applied, causes annulment of the compression on one side of the throat. See Figure B.1.

Figure B.1 Rotation and stress distribution at the throat

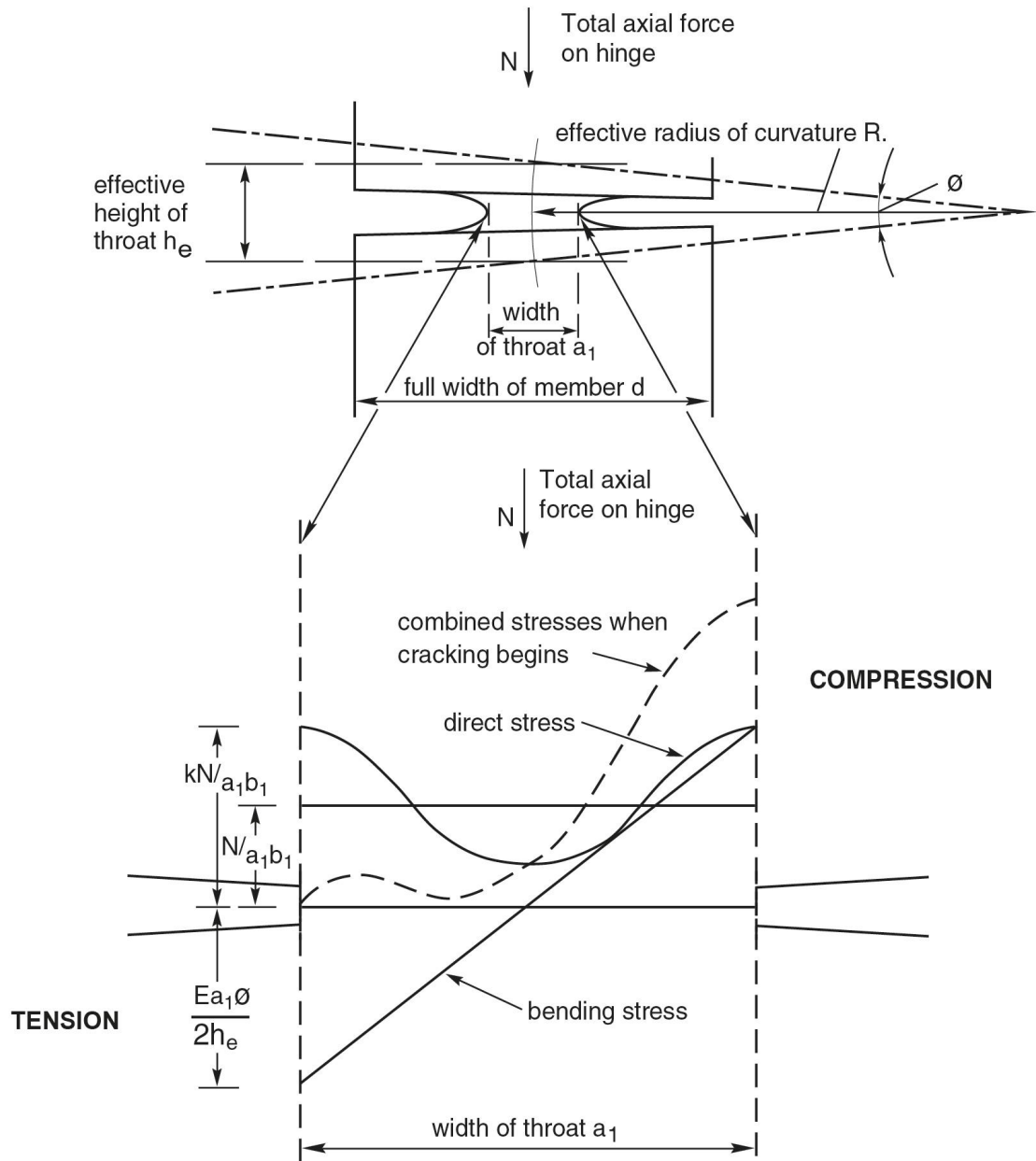

The stress distribution across the throat for an axial compressive load is of the form shown in Figure B.1, the maximum stresses being at the sides of the throat.

Tests showed that if this maximum stress is defined as $\frac{kN}{a_1b_1}$ then the notch factor, k , may be taken to be 1.5 for the range of tests carried out (i.e., for the throat widths up to 250 mm). This covers the range within which hinges have been used in highway bridges. Therefore maximum direct stress can be expressed as $\frac{1.5N}{a_1b_1}$

Let σ_b = the extreme fibre bending stress due to a superimposed moment in the hinge; then

$$\pm \frac{2\sigma_b}{a_1} = \frac{E}{R} = \frac{E\phi}{h_e}$$

$$\text{or } \sigma_b = \pm \frac{Ea_1\phi}{2h_e}$$

For no tensile stresses in the throat the maximum direct compressive stress at the sides has to be greater or equal to the maximum bending stress at any time. This is expressed as

$$\frac{1.5N}{a_1b_1} \geq \pm \frac{a_1}{2h_e} \times \sum E\phi$$

where: $\sum E\phi$ represents the sum, at any time, the products of rotation and modulus of elasticity for each type of loading.

It was found experimentally that h_e , the effective height of the throat, can be taken to be 125mm and hence the above expression may be rewritten as:

$$\frac{\sum E\phi}{N} \leq 1.5 \times \frac{2h_e}{a_1^2b_1} \approx \frac{380}{a_1^2b_1}$$

The value of the modulus of elasticity of the hinge for long-term rotations due to shrinkage, creep, elastic shortening and permanent loads is taken as being half that for temperature and variable loads.

If E_{cm} = modulus of elasticity for temperature and variable loads (kN/mm²); ϕ_s = total rotation due to variable loads and temperature (rads); and, ϕ_p = total rotation due to shrinkage, creep, elastic shortening and permanent loads (rads).

$$\begin{aligned} \text{Then } \sum E\phi &= E_{cm}\phi_s + \frac{E_{cm}}{2}\phi_p \\ &= E_{cm}\left(\phi_s + \frac{\phi_p}{2}\right) = E_{cm}\phi_e \end{aligned}$$

When the limiting value of zero tension on one side of the throat is reached it follows that the maximum compressive stress on the other side is $2 \times 1.5 \frac{N}{a_1b_1}$, i.e. three times the average compressive stress $\frac{N}{a_1b_1}$. Testing showed that under these conditions working values of the average compressive stress may safely be as much as twice the 28 day cube strength of the concrete or 105 N/mm², whichever is the lesser.

B2 Circular hinge

The assessment of circular hinges is based on recommendations by Crossley given in Crossley 1977 [Ref 3.I].

Based on an assumed stress distribution, Crossley determined that for no tension to develop on a circular throat $d_1 < \left(\sqrt[3]{\frac{1.7Nh_e}{0.5E\phi}}\right)$.

Safe load/rotation envelope was derived from the test results on circular hinges.

The graph in Table B.1 gives load/rotation combinations on a chart of $\frac{N}{f_{cu}d_1^2}$ versus ϕ_e by Crossley in Crossley 1977 [Ref 3.I].

Table B.1 also provides guidance on the expected performance and condition of the throat in terms of the acceptable damage to the throat concrete for any applied axial load and corresponding hinge rotation.

The chart is useful for comparing information obtained during hinge inspections with assessment calculation results especially where the throat is visible.

On the basis of the test results, areas A, A¹, B, and B¹ are acceptable for serviceability limit state assessments.

In areas C, C¹ where the mean stress on the throat is less than $2f_{cu}$, there is a possibility that damage of the throat face can be progressive particularly under repeated loading indicating the onset of failure at serviceability limit state.

Theoretically areas A¹, B¹, and C¹ can be extended to $\frac{N}{f_{cu}d_1^2} = 0$ but the experimental points have been kept to practical values of N .

Table B.1 Chart of loading/rotation combinations with possible condition of throat concrete

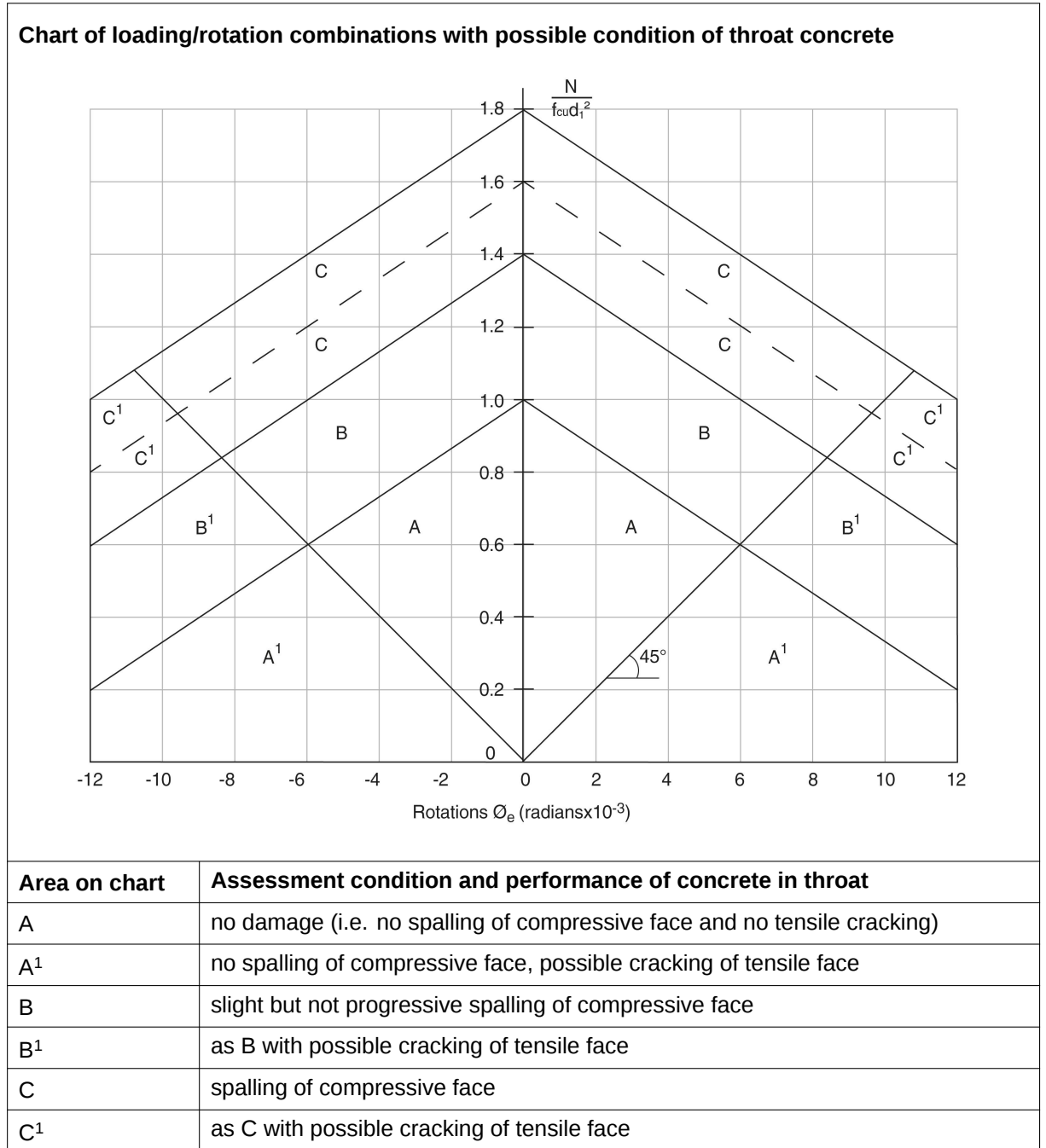

© Crown copyright 2020.

You may re-use this information (not including logos) free of charge in any format or medium, under the terms of the Open Government Licence. To view this licence:

visit www.nationalarchives.gov.uk/doc/open-government-licence/,
write to the **Information Policy Team, The National Archives, Kew, London TW9 4DU**,
or email psi@nationalarchives.gsi.gov.uk.